

ANTAU

2-WAY PRESSURE BALANCED SHOWER SYSTEM

SET.AU.210.210.CC

Components Included

- **VE.210** - Pressure balanced valve with integrated 2-way diverter
- **TM.AU.210.CC** - Trim for 2-way pressure balanced valve
- **SH.04.0812.CC** - 8" x 12" rectangular stainless steel shower head
- **WA.01.16.CC** - 16" wall mount shower arm with ½" female NPT connection
- **BH.04.03.CC** - 27½" sliding shower bar with hose and 4-function hand shower (HS.04.03.CC)
- **EC.01.01.CC** - Square brass elbow connector with ½" female NPT connection

Available Finishes

- Chrome

Codes / Standards

- Uniform Plumbing Code (UPC®)
- ASME A112.18.1/CSA B125.1
- ASSE 1016

Warranty

- Valve & cartridge - Limited lifetime warranty
- Components - Limited lifetime warranty (see full warranty for details)



ANTAU

2-WAY PRESSURE BALANCED VALVE & TRIM

VT.AU.210.CC

Description

- **VE.210** - 1/2" pressure balanced valve with 2-way diverter
- **TM.AU.210.CC** - Trim for 2-way pressure balanced valve
- 3 positions

Flow Rate

- 5.5 gpm | 21 lpm | 60 psi

Cartridge

- CE.1440.PB - cartridge
- CE.1403.DR - diverter

Available Finishes

- Chrome (CC)

Codes / Standards

- Uniform Plumbing Code (UPC®)
- ASME A112.18.1/CSA B125.1
- ASSE 1016

Warranty

- Limited lifetime warranty (see full warranty for details)

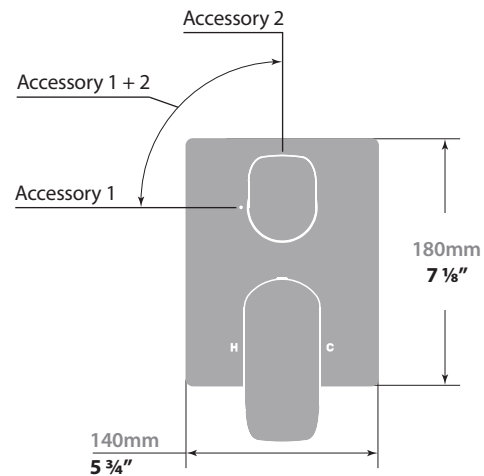

VE.210 - 2-Way Pressure Balanced Valve

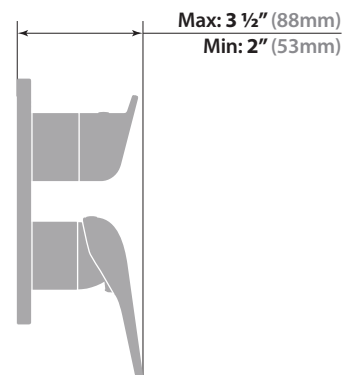
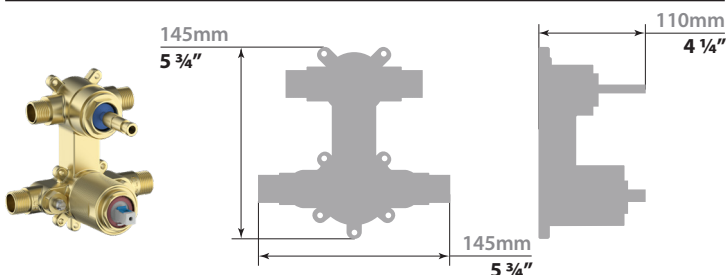

2-WAY PRESSURE BALANCED VALVE

VE.210

Description

- Valve with pressure balanced cartridge and 2-way diverter
- ½" male NPT connections

Flow Rate

- 5.5 gpm | 21 lpm | 60 psi

Cartridge

- CE.1440.PB cartridge
- CE.1403.PD diverter

Warranty

- Lifetime warranty
(see full warranty for more details)

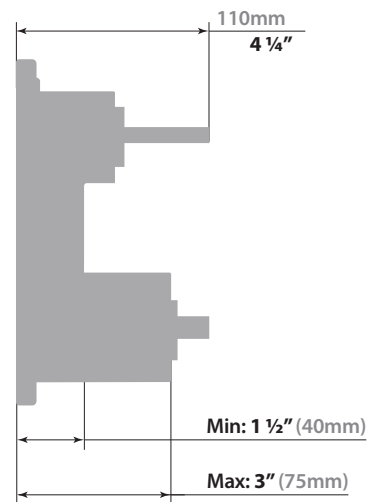
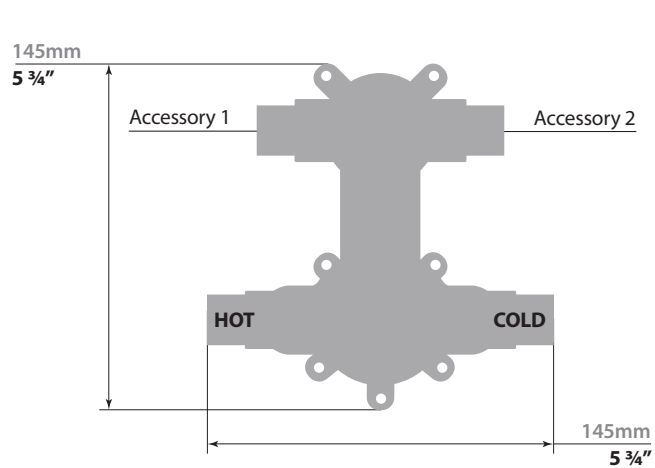
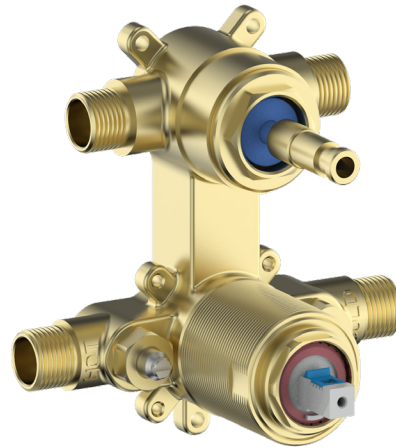

16" WALL ARM

WA.01.16

Description

- 16" wall mount shower arm with 1/2" female NPT connection
- Square pipe with rectangular escutcheon plate

Available Finishes

- Chrome (CC)
- Brushed Nickel (BN)
- Matte Black (MB)

(Model Pictured: Chrome)

Codes / Standards

- Uniform Plumbing Code (UPC®)
- ASME A112.18.1/CSA B125.1

Warranty

- Limited lifetime warranty (see full warranty for details)

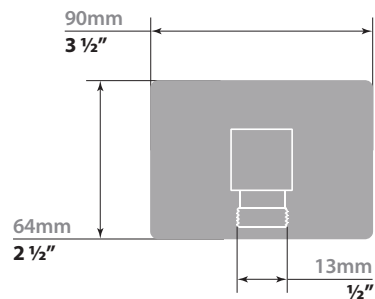
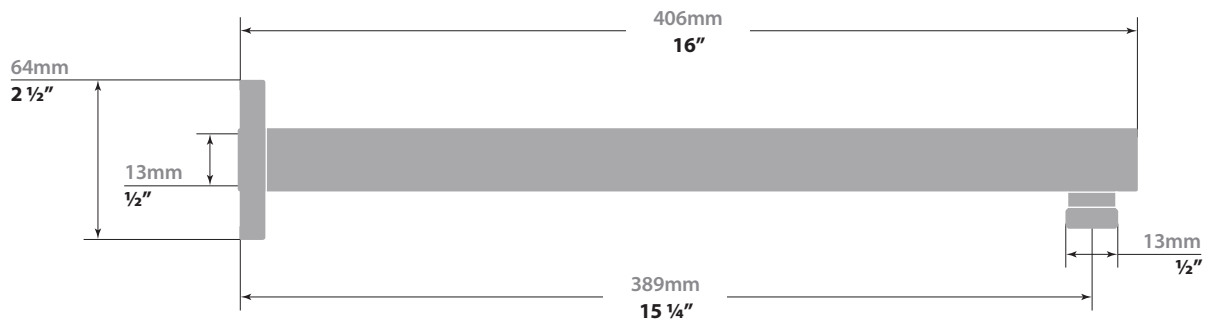
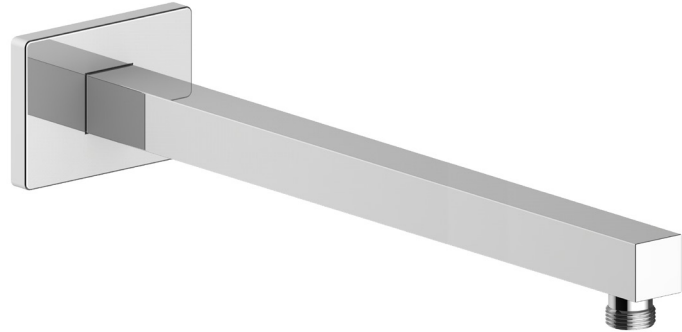

8" x 12" RECTANGULAR SHOWER HEAD

SH.04.0812.CC

Description

- 8" x 12" rectangular stainless steel shower head
- Anti-limescale technology

Flow Rate

- 2 gpm | 7.6 lpm | 60 psi

Available Finishes

- Chrome (CC)

Codes / Standards

- Uniform Plumbing Code (UPC®)
- ASME A112.18.1/CSA B125.1

Warranty

- Limited lifetime warranty (see full warranty for details)

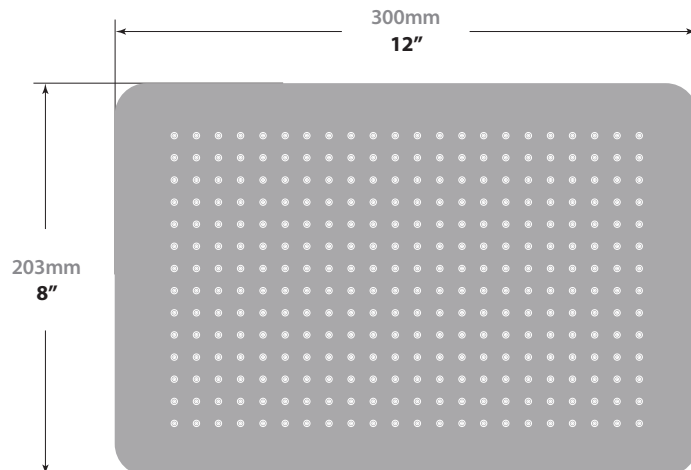
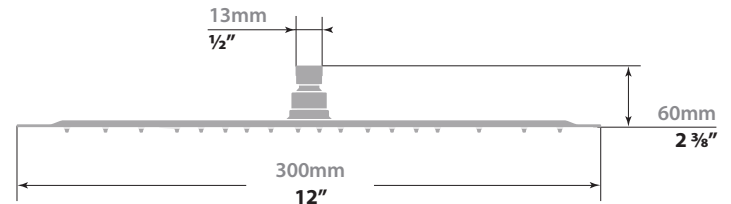
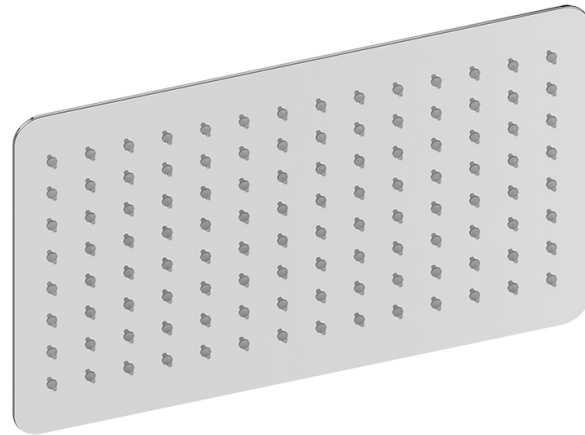

ANTAU

SLIDING SHOWER BAR WITH HANDFLOWER

BH.04.03.CC

Description

- SB.04.27 - 27½" sliding shower bar
- HE.150 - 59" hose
- HS.04.03 - 4-function hand shower

Flow Rate

- 2 gpm | 7.6 lpm | 60 psi

Available Finishes

- Chrome (CC)

Codes / Standards

- Uniform Plumbing Code (UPC®)
- ASME A112.18.1/CSA B125.1
- ASSE 1016

Warranty

- Limited lifetime warranty
(see full warranty for details)



SQUARE WALL SUPPLY ELBOW

EC.01.01

Description

- Square brass elbow connector with ½" female NPT connection

Available Finishes

- Chrome (CC)
- Brushed Nickel (BN)
- Matte Black (MB)

(Model Pictured: Chrome)

Codes / Standards

- Uniform Plumbing Code (UPC®)
- ASME A112.18.1/CSA B125.1

Warranty

- Limited lifetime warranty (see full warranty for details)

