

WÖRGL

2-WAY PRESSURE BALANCED SHOWER SYSTEM

SET.OR.210.210

Components Included

- **VE.210** - Pressure balanced valve with integrated 2-way diverter
- **TM.WL.210** - Trim for 2-way pressure balanced valve
- **SH.42.0808** - 8" round shower head
- **WA.42.16** - 16" wall mount shower arm with ½" female NPT connection
- **BH.02.03** - 31" sliding shower bar with hose and 3 function hand shower (HS.02.03)
- **EC.42.01** - Round elbow connector with ½" female NPT connection

Available Finishes

- Chrome (CC)
- Matte Black (MB)

(Model Pictured: Chrome)

Codes / Standards

- Uniform Plumbing Code (UPC®)
- ASME A112.18.1/CSA B125.1
- ASSE 1016

Warranty

- Valve & cartridge - Limited lifetime warranty
- Components - Limited lifetime warranty (see full warranty for details)



Please note that this shower kit is also available with a 4" ceiling arm (**CA.02.04**) & 8" ceiling arm (**CA.02.08**)

4" ceiling arm Configuration - **SET.OR.220.214**

8" ceiling arm Configuration - **SET.OR.220.218**

WÖRGL

2-WAY PRESSURE BALANCED VALVE & TRIM

VT.WL.210

Description

- **VE.210** - ½" pressure balanced valve with 2-way diverter
- **TM.WL.210** - Trim for 2-way pressure balanced
- 3 positions

Flow Rate

- 5.5 gpm | 21 lpm | 60 psi

Cartridge

- CE.1440.PB - cartridge
- CE.1403.DR - diverter

Available Finishes

- Chrome (CC)
- Brushed Nickel (BN)
- Matte Black (MB)

(Model Pictured: Chrome)

Codes / Standards

- Uniform Plumbing Code (UPC®)
- ASME A112.18.1/CSA B125.1
- ASSE 1016

Warranty

- Limited lifetime warranty (see full warranty for details)

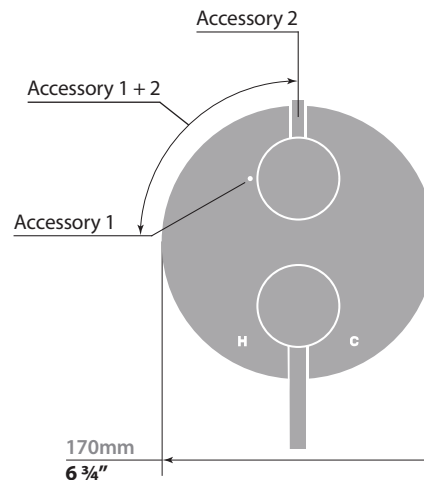
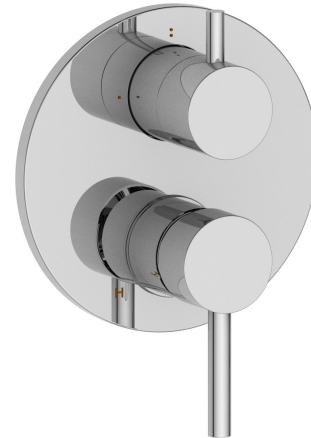

VE.210 - 2-Way Pressure Balanced Valve

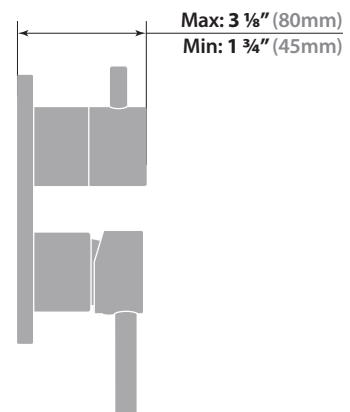
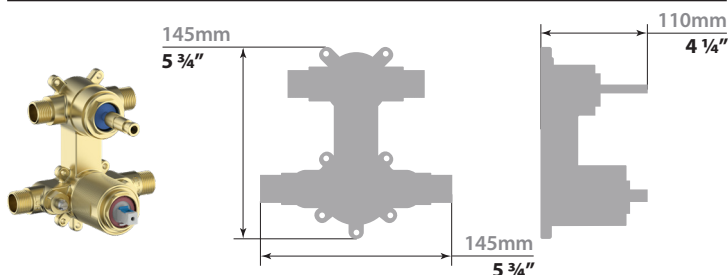

2-WAY PRESSURE BALANCED VALVE

VE.210

Description

- Valve with pressure balanced cartridge and 2-way diverter
- ½" male NPT connections

Flow Rate

- 5.5 gpm | 21 lpm | 60 psi

Cartridge

- CE.1440.PB cartridge
- CE.1403.DR diverter

Codes / Standards

- Uniform Plumbing Code (UPC®)
- ASME A112.18.1/CSA B125.1
- ASSE 1016

Warranty

- Limited lifetime warranty
(see full warranty for more details)

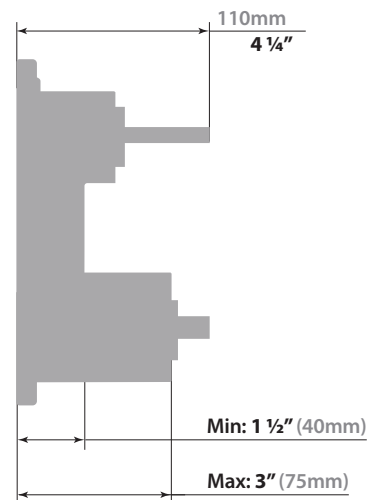
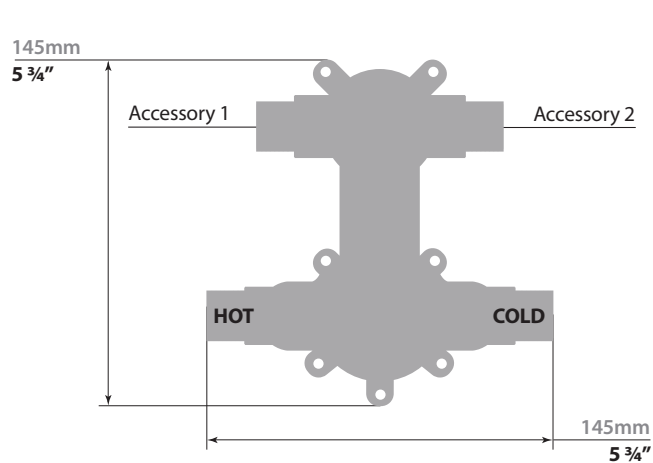
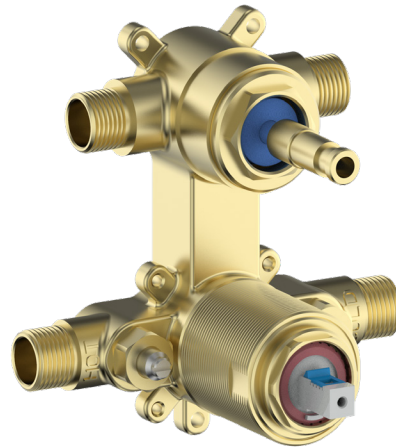

16" WALL ARM

WA.42.16

Description

- 16" wall mount shower arm with 1/2" female NPT connection
- Round pipe with round escutcheon plate

Available Finishes

- Chrome (CC)
- Matte Black (MB)

(Model Pictured: Chrome)

Codes / Standards

- Uniform Plumbing Code (UPC®)
- ASME A112.18.1/CSA B125.1

Warranty

- Limited lifetime warranty (see full warranty for details)

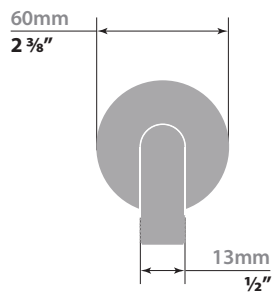
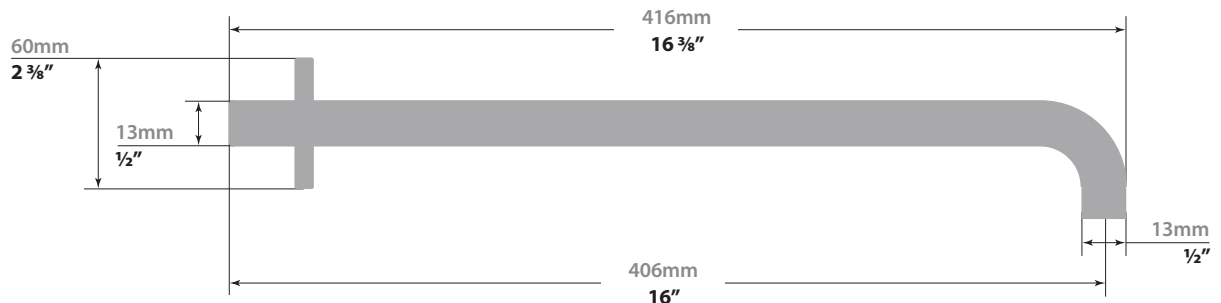
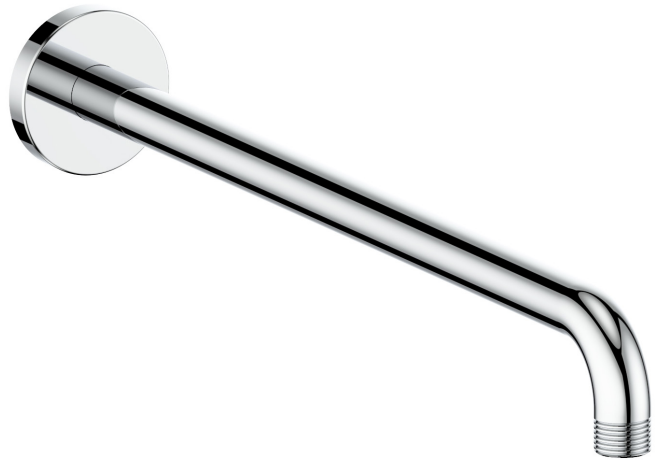

8" ROUND SHOWER HEAD

SH.42.0808

Description

- 8" round shower head
- Anti-limescale technology

Flow Rate

- 2 gpm | 7.6 lpm | 60 psi

Available Finishes

- Chrome (CC)
- Matte Black (MB)

(Model Pictured: Chrome)

Codes / Standards

- Uniform Plumbing Code (UPC®)
- ASME A112.18.1/CSA B125.1

Warranty

- Limited lifetime warranty
(see full warranty for details)

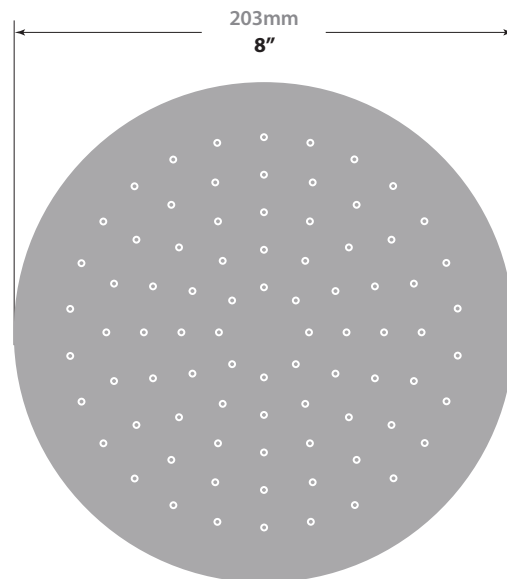
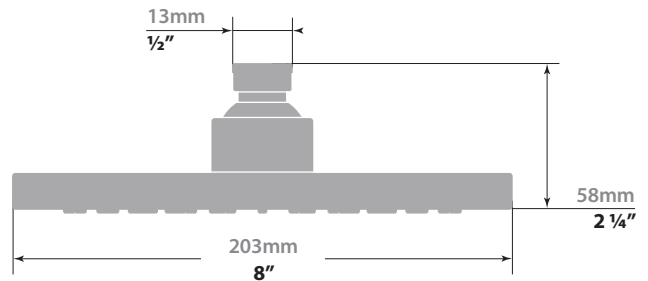

WÖRGL

SLIDING SHOWER BAR WITH HANDSHOWER

BH.02.03

Description

- SB.02.31 - 31" sliding shower bar
- HE.150 - 59" hose
- HS.02.03 - 3-function hand shower

Flow Rate

- 2 gpm | 7.6 lpm | 60 psi

Available Finishes

- Chrome (CC)
- Brushed Nickel (BN)
- Matte Black (MB)

(Model Pictured: Chrome)

Codes / Standards

- Uniform Plumbing Code (UPC®)
- ASME A112.18.1/CSA B125.1
- ASSE 1016

Warranty

- Limited lifetime warranty
(see full warranty for details)

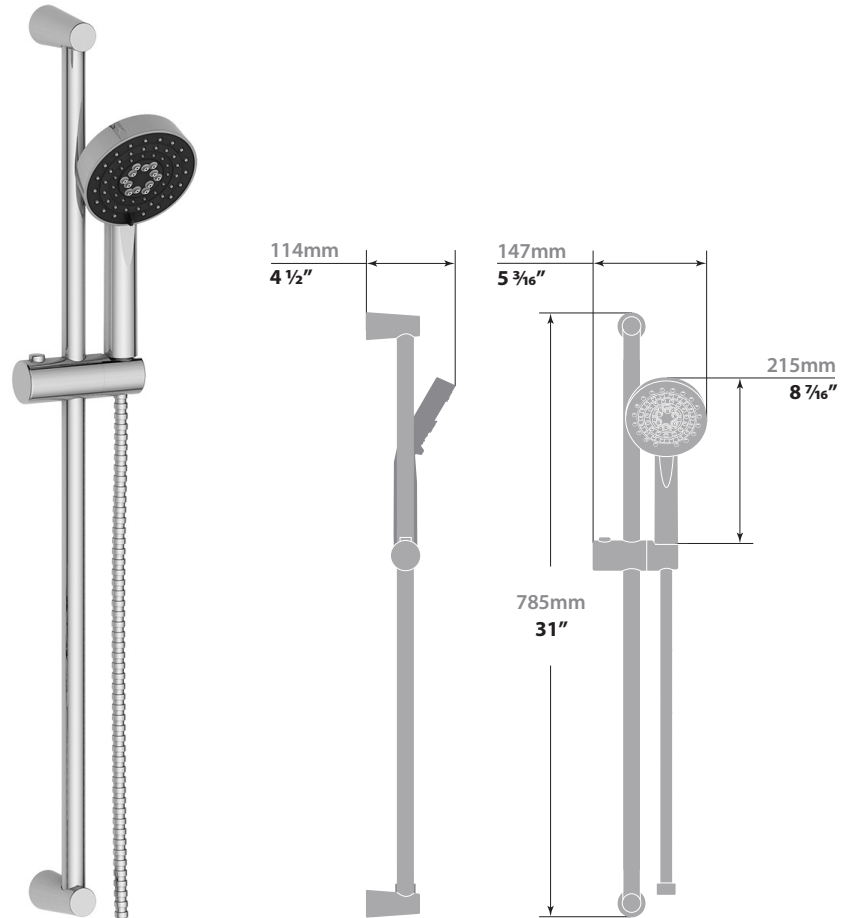

ROUND WALL SUPPLY ELBOW

EC.42.01

Description

- Round elbow connector with 1/2" female NPT connection

Available Finishes

- Chrome (CC)
- Matte Black (MB)

(Model Pictured: Chrome)

Codes / Standards

- Uniform Plumbing Code (UPC®)
- ASME A112.18.1/CSA B125.1

Warranty

- Limited lifetime warranty (see full warranty for details)

